

Subject : Inspection of the coolant pump

Effectivity : DG-800B, DG-500MB all ser. no.'s

Accomplishment : if necessary

Reason : In case the coolant temperature CHT exceeds the allowable limit of 95°C during climb, although there is enough coolant in the radiator and if bleeding doesn't improve the situation, the performance of the coolant pump should be checked.

Instructions : 1. Extend the engine
2. Remove the coolant hose (DG-800B: see MM diagr. 9 item 5 / DG-500MB see MM diagr. 12, item 4)) from the radiator (upper end). Insert the test adapter W59 into the hose and secure with a hose clamp. Install a PVC hose (instrument line) on the other end of the adapter and put its end in a calibrated container.
3. Switch on the ignition and measure the time needed to fill 0.2 liters into the container, then switch off the ignition immediately. Otherwise the pump will suck in air and bleeding may be difficult.
Normal time is between 15 and 20 seconds.
4. If the time needed exceeds 25 seconds the pump is worn and should be exchanged. Repeat the test after installation of the new pump.
5. In case the coolant doesn't come out of the hose but out of the radiator, the polarization of the pump wiring is wrong and the connectors must be interchanged. You find the connectors in the wiring close to the pump.
6. Remove the adapter and connect the coolant hose to the radiator again.
7. Open the radiator cap and fill in the coolant from the test, if necessary refill coolant.
8. Bleed the coolant circuit according to MM section 4.15.1.
Note: The pumps are delivered by DG with a plug connector at the positive wire and with a socket connector at the negative wire to minimize the risk of wrong polarization. With older DG-800B's this was not the case. In such case prior to installation of a new pump the aircraft wiring must be modified: Remove the socket connector from the negative wire (No. 17) and crimp on a 6,3mm plug connector.
Note: The times are applicable for room temperature. With lower temperatures the times will be somewhat longer.

Material : test adapter W59 and 0.5m PVC hose 5mm inside diameter
If necessary:
distilled water
Glycol
60001201 electric coolantpump Webasto U4810 modified
6,3mm plug connector
2 pieces of heat shrink tubing

Weight and balance : influence negligible

Remarks : All instructions may be executed by the owner.
A reference to this service info will be included to the manuals with the next manual revision.

Bruchsal, date:
July 12. 2002 amended Oct. 31.2002

Author:
Dipl. Ing. Wilhelm Dirks

Original situation		new pump	
Date		Date	
engine time		engine time	

tested time seconds

tested time seconds

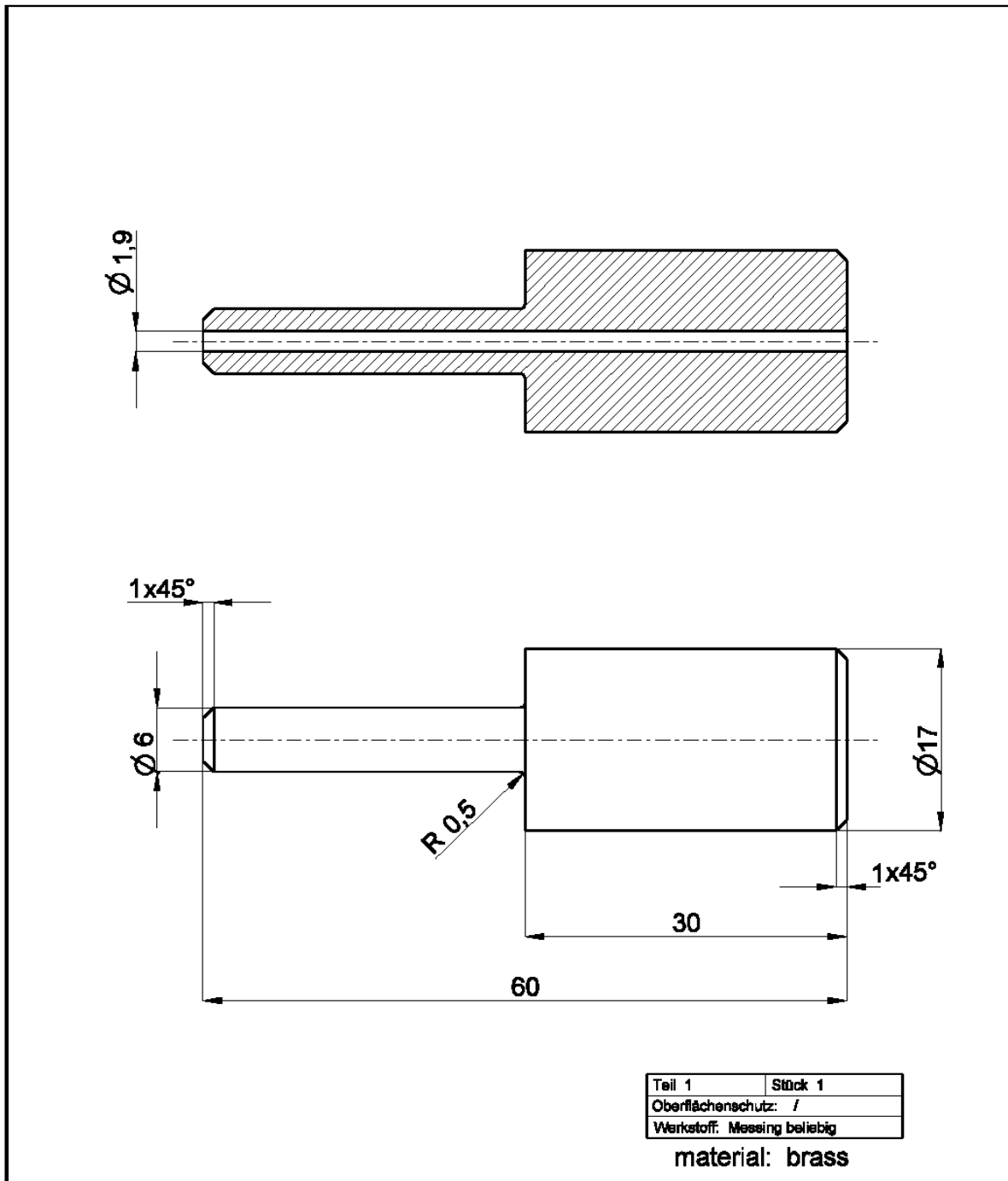

Toleranzen nach Arbeitsanweisung BA 1					Tag	Name	DG Flugzeugbau GmbH 76646 Bruchsal Otto-Lilienthal-Weg 2
Schweißen nach Arbeitsanweisung SA 1					Gez.	18.06.02 W. Dirke	
					Gep.		
					Norm.		 W59
					Maßstab	Prüfadapter test adapter	
					2:1		
					Maße ohne Toleranzang. nach:		
Ausz.	Änderung	AM	Tag	Name			